

Name _____

Date _____

Beginning Green Workbook B

Lesson 28, Part 1

Integral 66

Teacher: Have students print the words into the cakes and sandwiches. Make sure both of the letters **bl** go into the **thick** slice of bread or **thick** layer of cake. Any sandwich word can go into any sandwich, and any cake word can go into any cake. Make sure students understand that the order in which they see the words now is not the order that they go into the pictures. Students must stop and think about in which picture a word belongs.

blame bleak bleed

blade bleat blaze

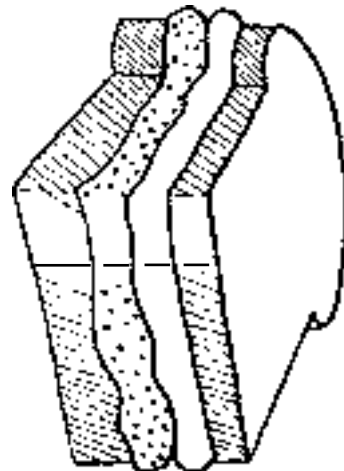
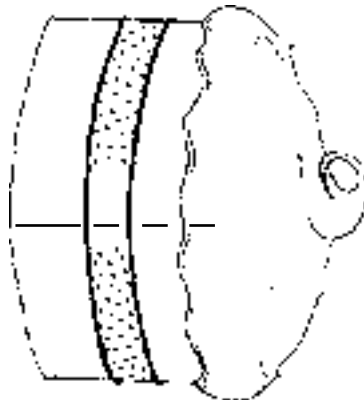
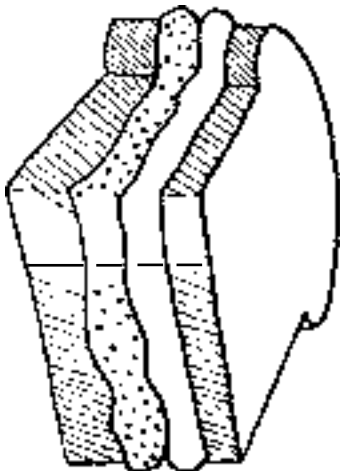
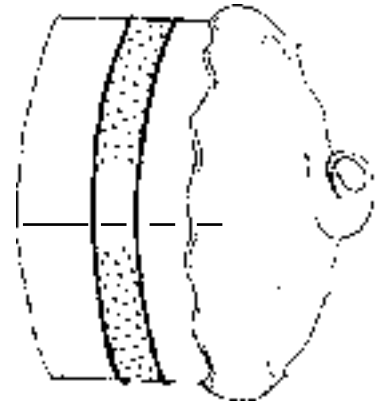
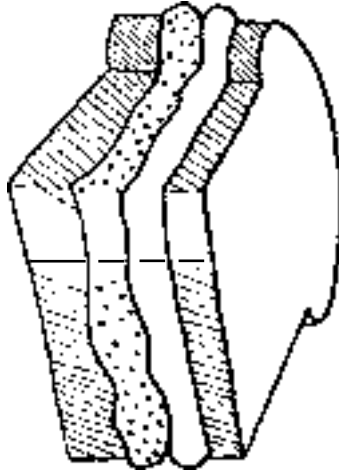
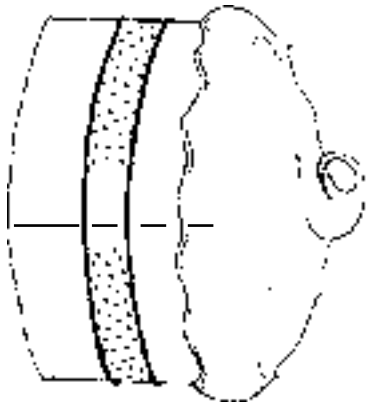

Name _____

Date _____

Beginning Green Workbook B

Lesson 28, Part 1

Integral 66

Teacher: Have students read each word in the list and circle only the words with the **thick** piece of bread or layer of cake. Then they print those words (only) into the appropriate picture. Finally, they print the word again under the picture, underline the vowel pattern and write it next to the word.

boat bleed bite blame bake
blaze bleat bleak

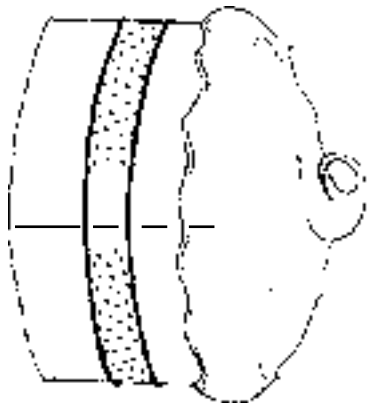

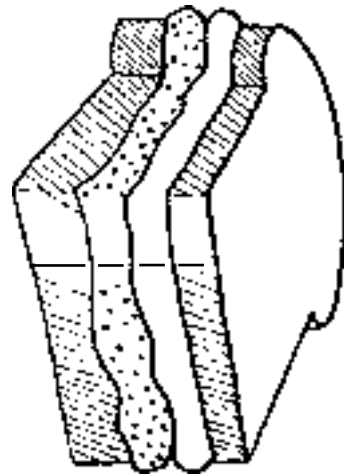

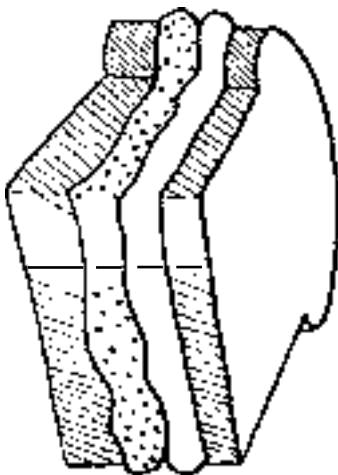

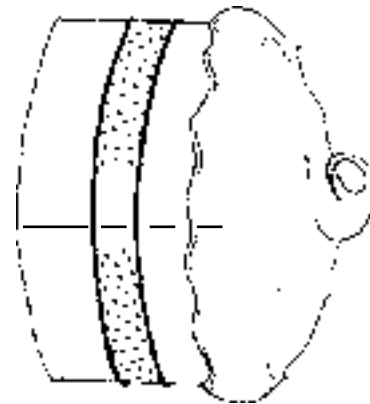

Name _____

Date _____

Beginning Green Workbook B

Lesson 28, Part 2

Integral 68

Teacher: Have students print the words into the cakes and sandwiches. Make sure both of the letters **br** go into the **thick** slice of bread or **thick** layer of cake. Any sandwich word can go into any sandwich, and any cake word can go into any cake. Make sure students understand that the order in which they see the words now is not the order that they go into the pictures. Students must stop and think about in which picture a word belongs.

brave brain broke

brace braid
bride

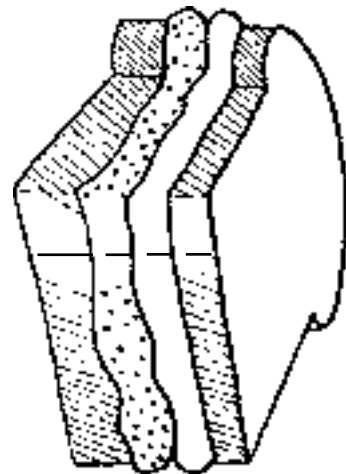
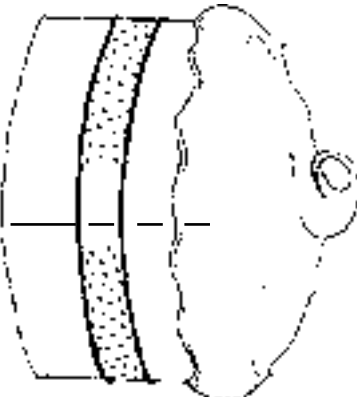
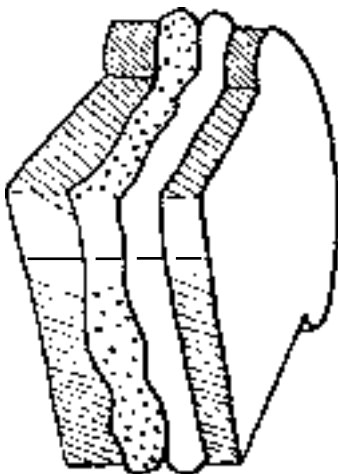
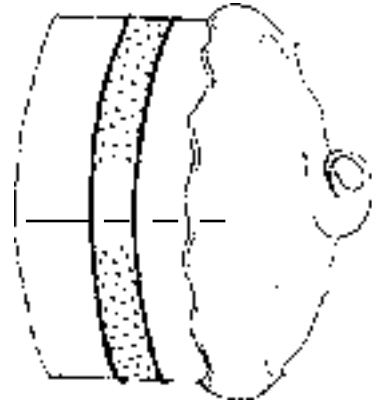
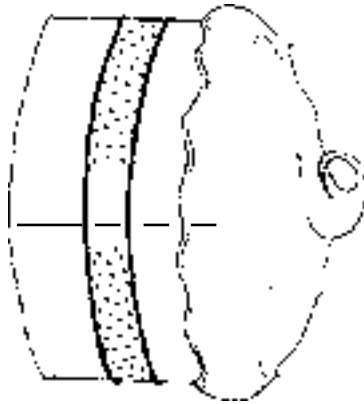
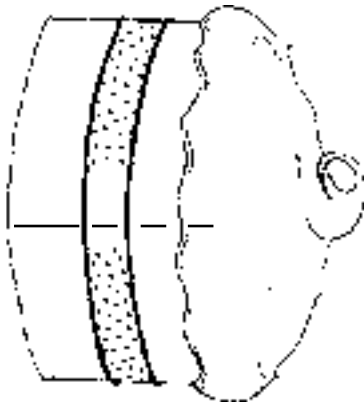

Name _____

Date _____

Beginning Green Workbook B

Lesson 28, Part 2

Integrals 66,68

Teacher: Have students circle every word that has a thick slice of bread or thick layer of cake, and only those words. Then students print the word on one of the lines below, underline the vowel pattern, and write the pattern next to the word. After pattern marking the word, students check off the word in the group. Students can proceed in any order. One word has been completed as an example.

bone brain
bleak bike brace
blame bean braid beef
base brave blare bail bake
blaze bead brine beam
bleed bait bride
bite broke

<u>brain</u>	ai		

Name _____

Date _____

Beginning Green Workbook B

Lesson 28, Part 3

Integrals 66,68

Teacher: Have students draw a line from the word to the picture to help demonstrate their reading comprehension. (Students should read the word first, then find the picture, not vice versa.)



i

blaze



bone



brain



bride

bike



boat

braid



beads



Name _____

Date _____

Beginning Green Workbook B **Lesson 28, Part 3** **Integrals 66,68**

Teacher: Students read the sentences, underline the correct word, and write it in the empty space.

1. The _____

_____ on the bike is fine.
bleed bleat brake

2. The _____

_____ from the fire was huge.
blaze brain blame

3. The soresg on my feet could _____

braid bleed bleak

4. The _____

_____ has a cute face.
bride blaze blare

5. It is a _____

_____ day.
blame bleak brace

6. I _____

_____ my bike on my way home.
bleat braid broke

7. I will pay you a fee to _____

----- my hair.
braid bleed broke

8. I could not _____

----- you for the hole in my tire.
blame brain blade